

**Motic®**

# AE30/31

## Epi-fluorescence Attachment for AE30 / 31 Inverted Microscopes

The system is exceptional at handling difficult fluorescence tasks,  
rendering images with outstanding clarity and exceptional contrast

**فرتاش داد** شرکت تحقیقاتی بازرگانی  
وارد کننده تجهیزات  
آزمایشگاهی، تحقیقاتی و آموزشی

تهران، خیابان آزادی، کوی مرمر، بلاک ۱۷۴، کد پستی: ۱۳۱۱۷  
صندوق پستی ۱۵۱-۱۴۱۸۵، تلفن: ۰۲۱-۶۶۴۲۹۹۵۵ (خط ۶)  
www.fartashdad.com فکس: ۰۲۱-۶۶۹۳۹۲۸۳  
E-mail: fartashdad@neda.net



AE31+Epi-fluorescence Attachment

# Combining the Motic AE30/31 CCIS optics with the unique design of epi-fluorescence attachment, a fluorescence image of excellent brightness and sharpness over an extended field of view of FN22 is achieved.

The Motic Epi-Fluorescence microscope is rapidly becoming an invaluable tool of investigation. Its advantages are upon features not readily available in other optical microscopes.

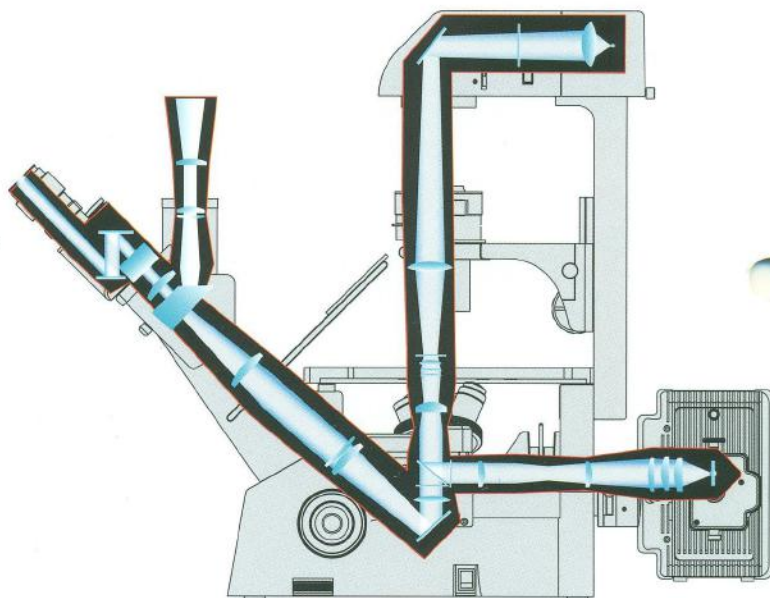

## Fluorescence equipment



## Fluorescence filter modules

FITC FITC/RSGFP/Fluo 3/  
DiO Acradine Orange(+RNA)  
**AZ1000073**

DAPI and Hoechst  
**AZ1000072**

Cy5, Alexa Fluor 633,  
Alexa Fluor 647  
**AZ1000076**

Cyan GFP  
**AZ1000077**



TRITC (Rhodamine)/  
Dil/Cy3  
**AZ1000074**

Texas Red® / Cy3.5  
**AZ1000075**

Yellow GFP BP  
(10C/Topaz)  
**AZ1000079**

Endow GFP  
Bandpass Emission  
**AZ1000078**

## Fluorescence filter specifications

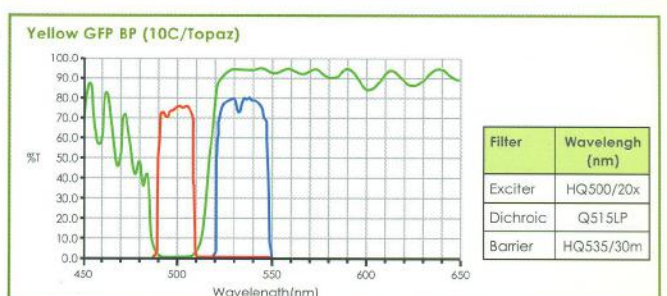
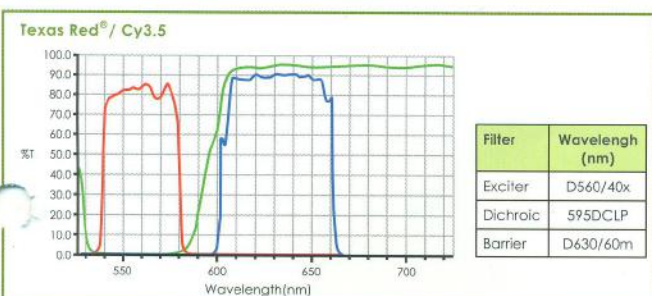
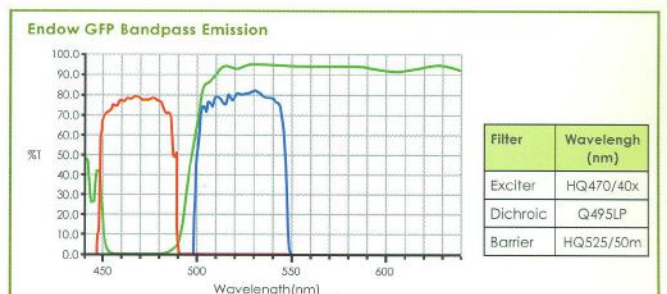
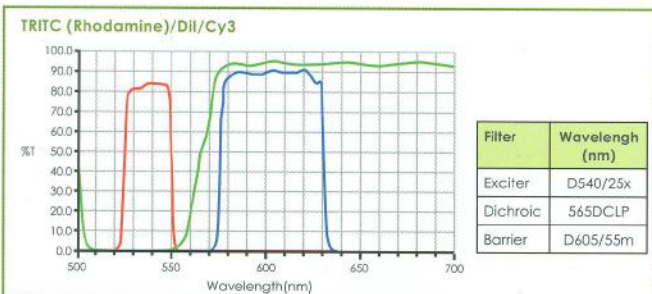
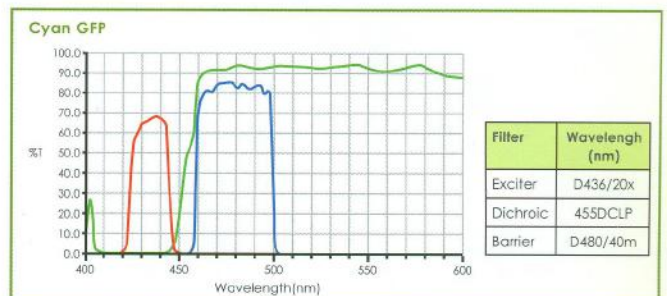
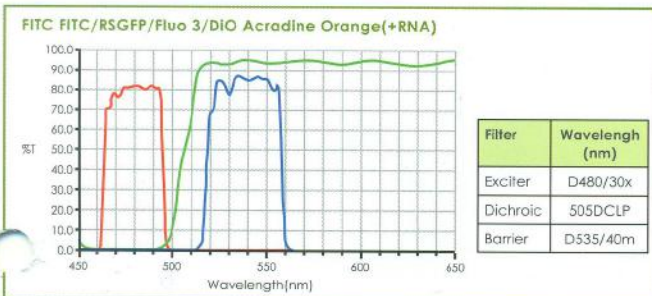
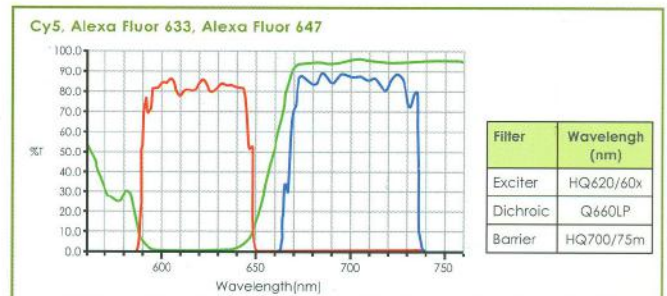
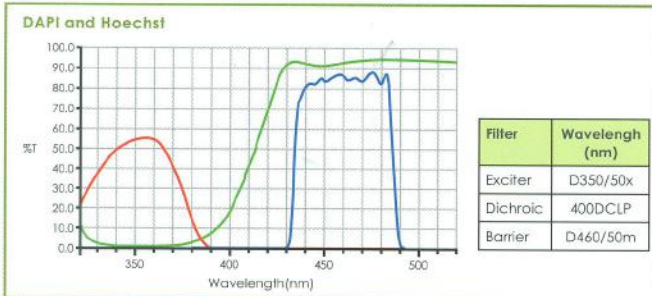

# Motic Epi-Fluorescence AE30/31 Assembly

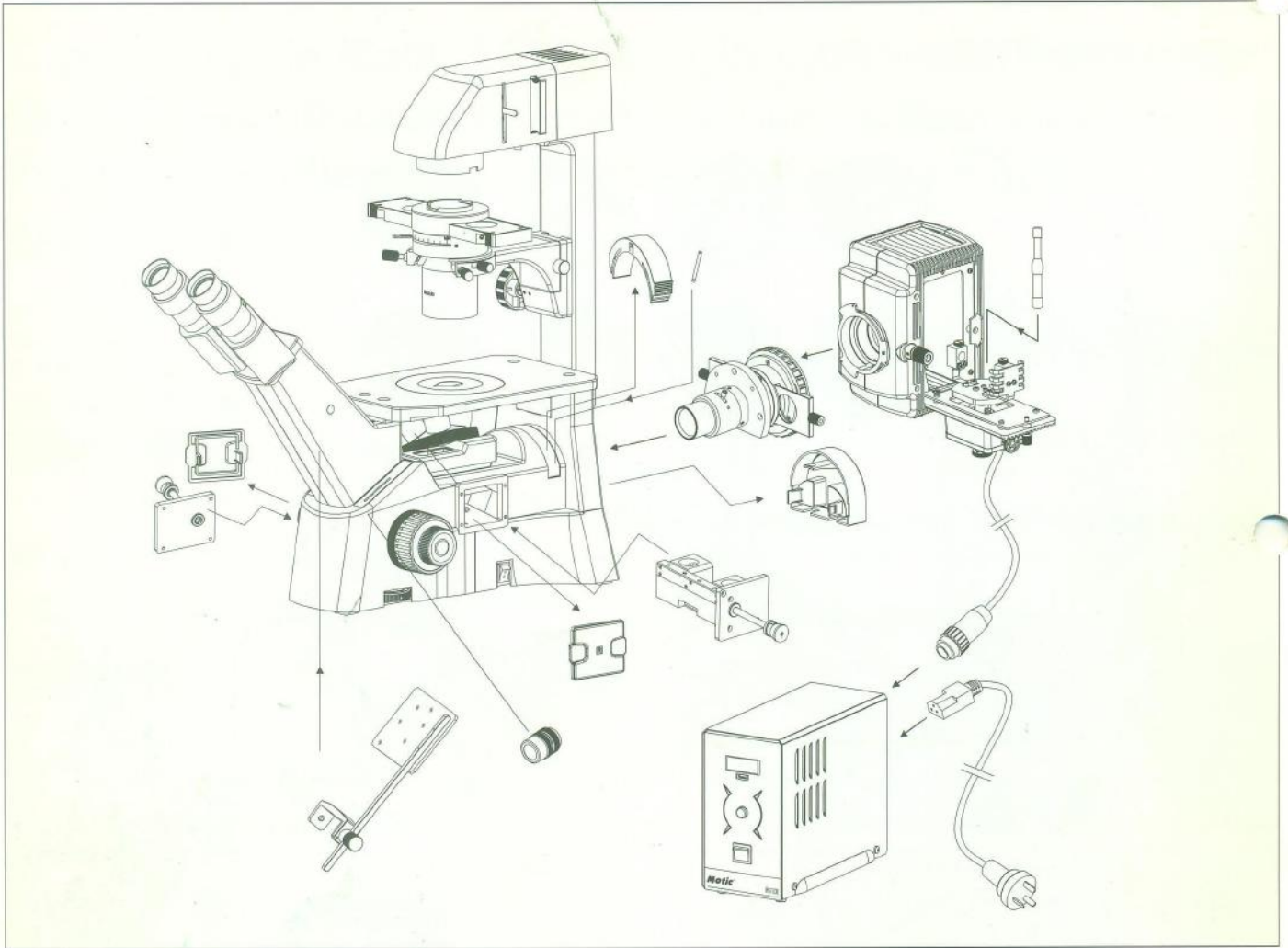

**Motic**

www.motic.com

Motic Incorporation  
Rm 2907-8, Windsor Park  
Tel: 852-2837 0888

Motic Instruments Inc.  
180-4320 Viking Way  
Tel: 1-877-977 4717

Motic Spain, S.L. (S.P.A.)  
Poligon Industrial Le  
Tel: 34-93-756 6286

Motic Deutschland  
Gewerbepark Spilb  
Tel: 49-6441-210 010 Fax 49-6441-210 0122

For inquiries in UK (UK)

Saracens House, 25 St. Margarets Green, Ipswich, IP4 2BN, Suffolk, UK  
Tel: 44-(0)-14732 81909 Fax 44-(0)-14732 11508

Motic Incorporation Ltd. Copyright © 2002-2004. All Rights Reserved

Design Change: The manufacturer reserves the right to make changes in instrument design in accordance with scientific and mechanical progress, without notice and without obligation.

**فرتاش داد**  
شرکت تحقیقاتی بازرگانی  
وارد کننده تجهیزات  
آزمایشگاهی، تحقیقاتی و آموزشی

تهران، خیابان آزادی، کوی مرمر، پلاک ۱۷۴، کدپستی: ۱۳۱۱۷  
صندوق پستی ۱۵۱-۱۴۱۸۵، تلفن: ۰۲۱-۶۶۴۲۹۹۵۵ (۶ خط)  
www.fartashdad.com فکس: ۰۲۱-۶۶۹۳۹۲۸۳  
E-mail: fartashdad@neda.net

CE

**Motic** Certified ISO 9001  
Certified ISO 14001

Code No: SP010812B